

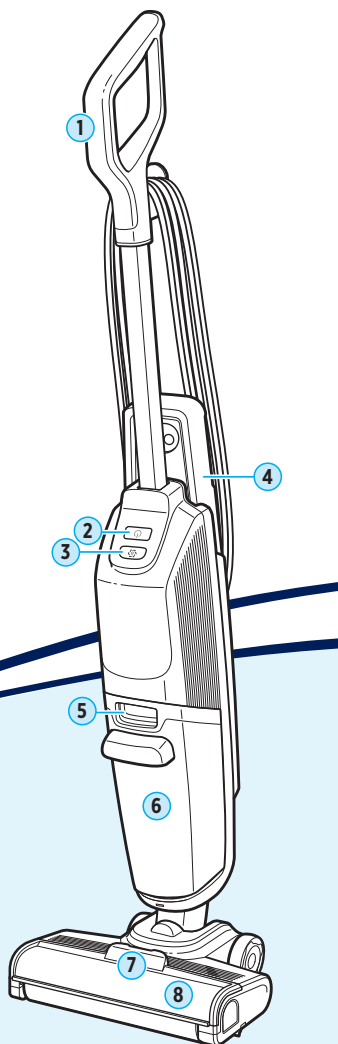











CROSSWAVE® HF2 WET & VACUUM HARD FLOOR CLEANER 3847 SERIES





Important Safety Instructions.....2
What's in the Box?.....3
Assembly.....3
Filling the Clean Water Tank.....4
Cleaning Your Floors.....5
Emptying the Dirty Water Tank.....6
Using the Clean-Out Cycle.....7
After-Cleaning Care.....8
Changing the Brush Roll.....9
Storing Your Machine.....9
Troubleshooting.....10
Limited Warranty.....11



Product Overview

- 1. Handle
- 2. Power Button
- 3. Clean-Out Cycle Button
- 4. Clean Water Tank
- 5. Dirty Water Tank
- 6. Dirty Water Tank with Filter
- 7. Brush Roll Window Release Button
- 8. Brush Roll Window

SYMBOL	EXPLANATION
	Caution.
	Read operator's manual.
	Risk of fire.
	Risk of electric shock.
	For indoor use only.
	Use only BISSELL® cleaning formulas intended for use with this machine.
	Disconnect power before servicing.
	Allow parts to dry.
	Use warm water, temperature up to 60°C.
	Do not freeze.

SYMBOL	EXPLANATION
	Check the manufacturer's tag before cleaning textile. "W" on the tag as shown means you can use your cleaner.
	This symbol on the product and/or accompanying documents means that used electrical and electronic products should not be mixed with general household waste. For proper treatment, recovery and recycling, please take this product to designated collection points. Please contact your local authority for further details of your nearest designated collection point.
	Protection against moving parts.
	Risk of automatic start-up.
	Clean-out cycle. Automatic self-cleaning cycle after use.

IMPORTANT SAFETY INSTRUCTIONS

READ ALL INSTRUCTIONS BEFORE USING YOUR APPLIANCE.

When using an electrical appliance, basic precautions should be observed, including the following:

WARNING

TO REDUCE THE RISK OF FIRE, ELECTRIC SHOCK OR INJURY:

- This appliance can be used by children aged from 8 years and above and persons with reduced physical, sensory or mental capabilities or lack of experience and knowledge if they have been given supervision or instruction concerning use of the appliance in a safe way and understand the hazards involved. Cleaning and user maintenance shall not be made by children without supervision.
- Children should be supervised to ensure that they do not play with the appliance.
- Keep hair, loose clothing, fingers, and all parts of body away from openings and moving parts of the appliance and its accessories.
- If the supply cable is damaged, it must be replaced by the manufacturer, its service agent or similarly qualified person in order to avoid a hazard.
- A hazard may occur if the appliance runs over the supply cord.
- Do not use with damaged cable or plug.
- Do not pull or carry by cable, use cable as a handle, close door on cable, or pull cable around sharp edges or corners.
- Keep cable away from heated surfaces.
- If the appliance has a hand held accessory like pet brush, motor driven head, etc., the user shall avoid entrapment.

- Do not leave appliance when plugged in.
- Use only the type and amount of liquids specified under the operations section of this guide.
- Liquid must not be directed towards equipment containing electrical components.
- Always connect to a properly earthed electrical socket. Do not modify earthed plug.
- To unplug, grasp the plug, not the cable.
- Do not handle plug or appliance with wet hands.
- Turn OFF all controls before unplugging.
- Plastic film can be dangerous. To avoid danger of suffocation, keep away from children.
- Use only as described in this user guide.
- Use only manufacturer's recommended attachments.
- If appliance is not working as it should, has been dropped, damaged, left outdoors, or dropped into water; do not attempt to operate it and have it repaired at an authorised service center.
- Do not put any object into openings.
- Do not use with any opening blocked; keep free of dust, lint, hair, and anything that may reduce air flow.
- Use extra care when cleaning on stairs.
- Do not use to pick up flammable or combustible liquids, such as petroleum, or use in areas where they may be present.

- Do not pick up toxic material (chlorine bleach, ammonia, drain cleaner, etc.).
- Do not use appliance in an enclosed space filled with vapours given off by oil-based paint, paint thinner, some moth-proofing substances, flammable dust, or other explosive or toxic vapours.
- Do not pick up hard or sharp objects such as glass, nails, screws, coins, etc.
- Do not pick up anything that is burning or smoking, such as cigarettes, matches or hot ashes.
- Do not use without filters in place.
- Floor slippery when wet.
- Use indoors only.
- The plug must be removed from the socket-outlet before cleaning or maintaining the appliance, and if your appliance has an accessory tool with a moving brush, before connecting or disconnecting the tool.
- If your appliance is fitted with a nonrewireable BS 1363 plug it must not be used unless a 13 amp (ASTA approved to BS 1362) fuse is fitted in the carrier contained in the plug. Spares may be obtained from your BISSELL supplier. If for any reason the plug is cut off, it must be disposed of, as it is an electric shock hazard should it be inserted into a 13 amp socket.
- Do not turn your appliance ON until you are familiar with all instructions and operating procedures.

SAVE THESE INSTRUCTIONS

ORIGINAL INSTRUCTIONS.





FOR OPERATION ON A 220-240 VOLT A.C. 50-60 HZ POWER SUPPLY ONLY.

THIS MODEL IS FOR HOUSEHOLD USE ONLY.

IMPORTANT INFORMATION

- Keep appliance on a level surface.
- If your appliance has a motorised brush roll, do not leave machine running in the same spot without the handle fully upright.
- To reduce the risk of a leaking condition, do not store unit where freezing may occur. Damage to internal components may result.
- Plastic tanks are not dishwasher safe. Do not put tanks in dishwasher.

What's in the Box?

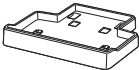
				
Body	Handle	Clean Tank	BISSELL® Trial Cleaning Solution	Tray

Assembly



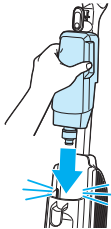
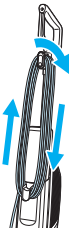

		
1. Insert handle until it clicks into place.	2. Insert clean tank into back of machine until it clicks into place.	3. Wrap cord. To easily unwrap, turn Quick Release™ Cord Wrap down.

Note: Remove cardboard insert from bottom of foot before first use.

Filling the Clean Water Tank

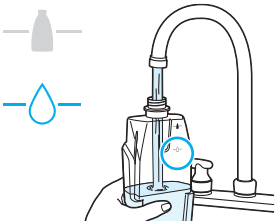
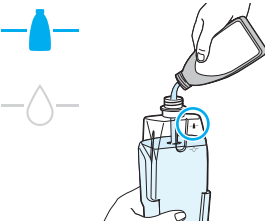
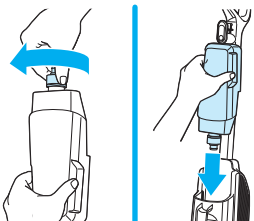

This machine is compatible with BISSELL® Crosswave® cleaning solutions made for wet & vacuum hard floor cleaners. Other cleaning solutions or household cleaners may harm the machine.

		
<p>1. Choose a cleaning solution.*</p>	<p>2. Pull clean water tank up to remove.</p>	<p>3. Unscrew cap.</p>
		
<p>4. Fill clean water tank with warm water (60°C Max) to water fill line.</p>	<p>5. Add cleaning solution* to the cleaning solution line.</p>	<p>6. Screw cap back on. Align clean water tank with grooves on back of machine and slide it until it clicks into place.</p>

*Compatible BISSELL cleaning solutions include: Natural Multi-Surface Cleaning Solution, Natural Multi-Surface Pet Cleaning Solution, Multi-Surface Cleaning Solution, Multi-Surface Pet Cleaning Solution, Wood Floor Cleaning Solution

⚠ WARNING To reduce the risk of fire and electric shock due to internal component damage, use only BISSELL cleaning fluid intended for use with the appliance.

Cleaning Your Floors

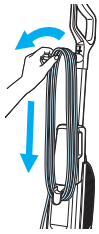

1. Unwrap cord. To easily unwrap, turn Quick Release™ Cord Wrap down.

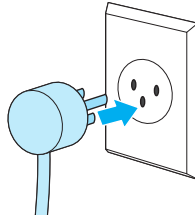

2. Plug in machine.

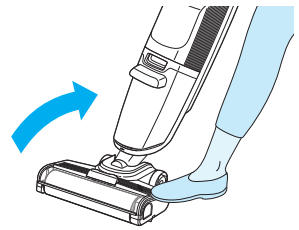

3. Recline machine.

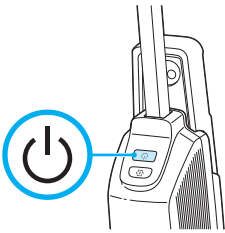

4. Press power button to turn machine ON.

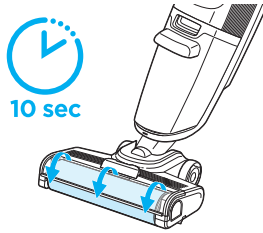

5. Brush roll starts spinning. Brush roll will not spin when machine is upright. The solution may take up to 10 seconds to fully wet brush roll.

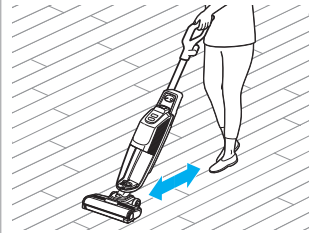

6. Use steady forward and backward strokes to ensure best performance.

Note: This product is intended for hard floor use only. Do not use on carpet or area rugs.

Emptying the Dirty Water Tank

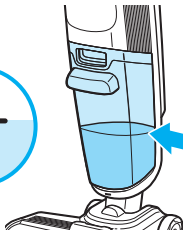

1. Empty dirty water tank when water reaches "MAX" line. Do not let water overflow.

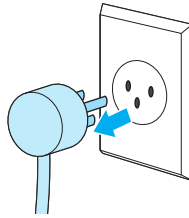

2. Turn power OFF and unplug machine.

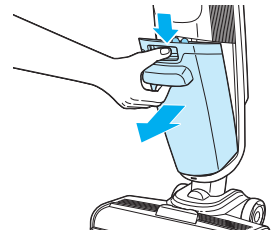

3. Press button on top of dirty water tank, grab front handle and pull out.

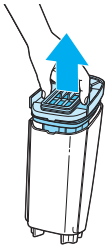

4. Hold top of tank and pull up to remove.

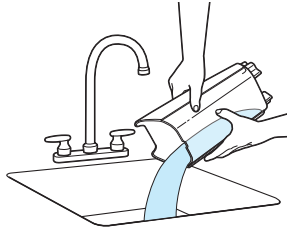

5. Pour dirty water into a sink or similar wastewater receptacle and thoroughly rinse tank.



6. Reinstall tank lid.

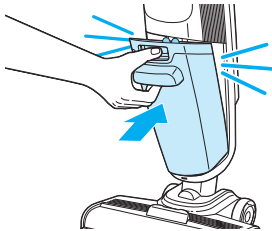

7. Insert bottom of tank first. Pivot top toward the machine until it clicks.

⚠ WARNING To reduce the risk of fire, electric shock or injury, turn power OFF and disconnect plug from electrical outlet before performing maintenance or troubleshooting.

Using the Clean-Out Cycle

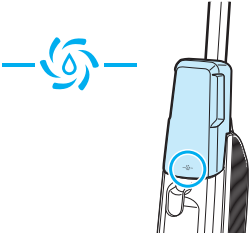
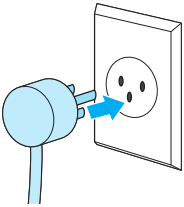
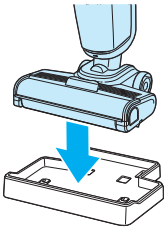
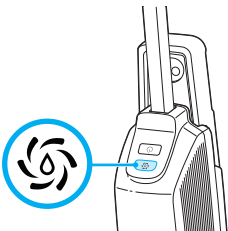
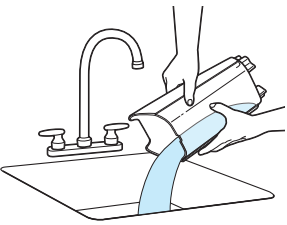

Note: Empty dirty water tank before beginning and make sure filter stays dry. Use clean-out cycle after each use.

		
<p>1. Make sure water reaches the clean-out cycle line on clean water tank. Refill with water if needed.</p>	<p>2. Plug in machine.</p>	<p>3. Place machine in storage tray. Note: Clean-out cycle will only run with machine in tray.</p>
		
<p>4. Press the clean-out cycle button to begin.</p>	<p>5. Pour dirty water into a sink or similar wastewater receptacle and thoroughly rinse tank.</p>	

⚠ WARNING To reduce the risk of fire, electric shock or injury, turn power OFF and disconnect plug from electrical outlet before performing maintenance or troubleshooting.

After-Cleaning Care

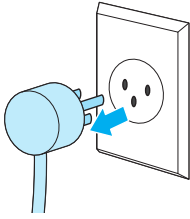

1. Turn power OFF and unplug machine.

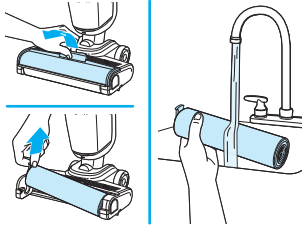

2. Remove brush roll window and brush roll following steps on page 9. Rinse brush roll.

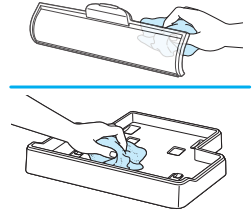

3. If brush roll window or tray are dirty, wipe excess dirt and water to clean.

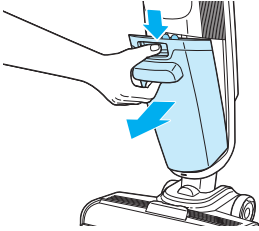

4. Press button on top of dirty water tank. Grip front handle and pull out to remove.

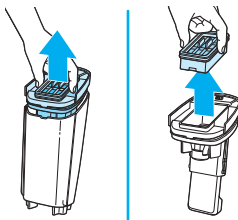

5. Pull up tank lid to remove filter assembly. Grip sides of filter to remove filter.

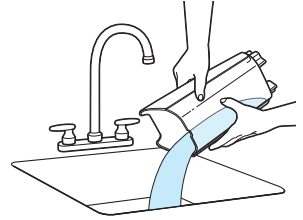

6. Empty dirty water tank following the steps on page 6.

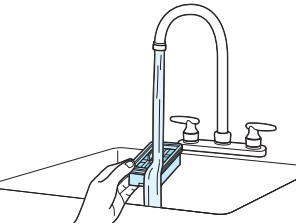

7. Wash filter in warm water and mild detergent.

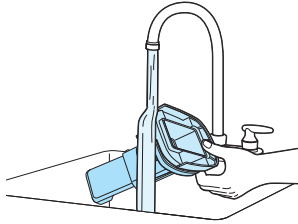

8. Rinse bottom of tank lid to remove debris.

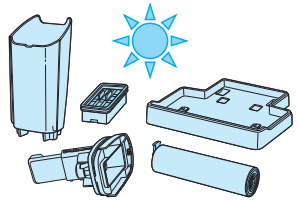

9. Let parts air dry for 24 hours before next use.

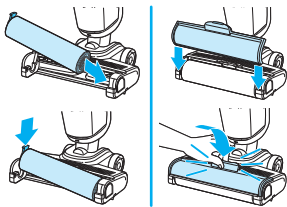

10. Reinstall brush roll and brush roll window following steps on page 9.

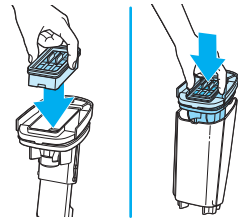

11. Reinstall filter and tank lid.

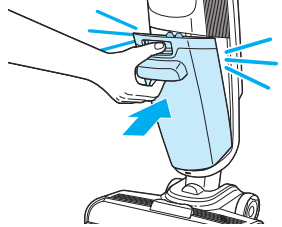

12. Reinstall dirty water tank. Insert bottom of tank first. Pivot top toward the machine until it clicks into place.

Changing the Brush Roll



<p>1. Press button and pull up on tab to remove brush window.</p>	<p>2. Pull tab to remove brush roll.</p>	<p>3. Reinstall brush roll. Place end of brush into right side of foot.</p>
<p>4. Press tab of brush down to lock into place.</p>	<p>5. Reinstall brush roll window. Align tabs on edges of foot.</p>	<p>6. Press window so it clicks into place.</p>

Storing Your Machine

<p>1. Wrap cord around cord wrap for storage.</p>	<p>2. Store machine indoors in a dry location.</p>

Note: Any other maintenance or servicing not included in this manual should be performed by an authorized service representative.

NOTICE To reduce the risk of a leaking condition, do not store machine where freezing may occur. Damage to internal components may result.

⚠ WARNING To reduce the risk of fire, electric shock or injury, turn power OFF and disconnect plug from electrical outlet before performing maintenance or troubleshooting.

Troubleshooting

Below are some of the issues you may run into. If you don't see the issue you're experiencing below, visit support.BISSELL.co.uk or contact BISSELL Consumer Care.

Problem	Possible Cause	Remedies
Reduced or no spray	Clean water tank may be empty or seated incorrectly.	Refill and reinstall the clean water tank.
	System isn't completely primed.	Allow machine to run for 15-20 seconds to fully prime.
	Brush window is not latched in place.	Unplug machine and reinstall brush window.
	Clean tank filter is dirty.	Remove clean tank from machine and locate small white foam filter under where the tank connects to the body. Clean any debris from foam filter and reinstall.
Loss of suction or streaking	Tanks may not be seated properly.	Remove both tanks and reseal them so they fit properly on machine.
	Dirty water tank is full.	Empty dirty water tank.
	Brush window is not latched in place.	Unplug machine and reinstall window.
	Debris channel in foot is clogged by debris.	Clean channel with a paper towel.
	Filter clogged by debris.	Remove debris clogging filter screen and clean filter.
Brush roll is not turning	Brush roll is not installed properly.	Follow instructions on page 9 for replacing brush roll.
	Machine is standing upright.	Step on foot and recline body of machine to turn brush roll on.
	Brush roll stalled by debris.	Unplug machine. Remove brush window and brush roll to remove obstruction.
Machine won't turn on	Brush roll stalled by debris.	Unplug machine. Remove brush window and brush roll to remove obstruction.
Machine is leaking	Cap of clean water tank is not closed properly.	Remove clean water tank and reinstall cap.
Brush roll stops turning unexpectedly and motor continues to operate	Machine is overheating.	Unplug machine from power and allow to cool for 30 minutes.



WARNING

To reduce the risk of fire, electric shock or injury, turn power OFF and disconnect plug from electrical outlet before performing maintenance or troubleshooting.

Limited Warranty

This limited warranty only applies outside of the USA, Canada, Australia, New Zealand, and mainland China. It is provided by BISSELL International Trading Company B.V. ("BISSELL") and gives you specific rights. It is offered as an additional benefit to your other rights under your local laws, which may vary from country to country. You can find out about your legal rights and remedies by contacting your local consumer advice service. Nothing in this warranty will replace or lessen any of your legal rights or remedies. If you need additional instruction regarding this warranty or have questions regarding what it may cover, please contact BISSELL Consumer Care or contact your local distributor.

This warranty is given to the current owner of the product with the original sales receipt. The original sales receipt must include the product(s) purchased, the date purchased, and which country it was purchased from new. You must be able to evidence the date of purchase and the country where the product was purchased to submit a claim under this warranty. You will receive the warranty that is applicable to the country where your product was originally purchased, as shown on the original sales receipt. If you use the product outside of the country where it was purchased, your warranty may be void in BISSELL's sole discretion. It may be necessary to obtain some of your personal information, such as a mailing address, to fulfill the terms of this warranty. Any personal data will be handled pursuant to BISSELL's Privacy Policy, which can be found at global.BISSELL.com/privacy-policy.

Limited 2-Year Warranty (varies by model)

For two years from the date of purchase by the original purchaser, subject to the EXCEPTIONS AND EXCLUSIONS* identified below, BISSELL will repair or replace (with new, refurbished, lightly used, or remanufactured components or products), at BISSELL's option, free of charge, any defective or malfunctioning part or product.

BISSELL recommends that the original packaging and original proof of purchase with the date of purchase and country where purchased be kept for the duration of the warranty period in case you want to redeem the warranty during the warranty period. Keeping the original packaging will assist with any necessary re-packaging and transportation but is not a condition of the warranty.

If your product is replaced by BISSELL under this warranty, then the new item will benefit from the remainder of the term of this warranty (calculated from the date of the original purchase). The period of this warranty shall not be extended whether or not your product is repaired or replaced.

*Exceptions and Exclusions from the Terms of the Warranty

This warranty applies to products used for personal domestic use and not commercial or hire purposes. Consumable components and attachments such as filters, belts, shells, water tanks, scraping strips, brushes, and mop pads, which must be replaced or serviced by the user from time to time, are not covered by this warranty. This warranty does not apply to any defect arising from fair wear and tear, including but not limited to the battery discharging time shortening due to the aging or use. Damage or malfunction caused by the user or any third party whether as a result of accident, negligence, abuse, neglect, or any other use not in accordance with the user guide is not covered by this warranty. An unauthorised repair (or attempted repair) may void this warranty whether or not damage has been caused by that repair/attempt. Removing or tampering with the Product Rating Label on the product or rendering it illegible will void this warranty.

Except as set out below, BISSELL and its distributors are not liable for any loss or damage that is not foreseeable or for incidental or consequential damages of any nature associated with the use of this product including without limitation loss of profit, loss of business, business interruption, loss of opportunity, distress, inconvenience, or disappointment. Except as set out below, BISSELL's liability will not exceed the purchase price of the product.

BISSELL does not exclude or limit in any way its liability for (a) death or personal injury caused by our negligence or the negligence of our employees, agents or subcontractors; (b) fraud or fraudulent misrepresentation; (c) or for any other matter which cannot be excluded or limited under law.

Important Notes

- If your BISSELL product should require service or to claim under our limited warranty, please visit global.BISSELL.com.
- Please keep your original sales receipt. It provides proof of the date of purchase and where it was purchased in the event of a warranty claim. See warranty for details.
- Please note that using your BISSELL machine outside of its country of original purchase and/or use with a power converter may damage your BISSELL machine and damage caused by mismatched power voltage will not be covered by your warranty.
- Please note that putting vinegar, bleach, dish soap, detergent, homemade soap, and other non-BISSELL products in your BISSELL machine may damage your BISSELL machine. Damage caused by using non-BISSELL products in your machine will not be covered by your warranty.

But wait, there's more!

Join us online for a complete guide to your new product, including troubleshooting, parts and more.

Go to support.BISSELL.co.uk.



INFO



VIDEOS



PARTS



©2023 BISSELL, Inc. All rights reserved.
Part Number 1636767 06/23 v5